



AQUATIC
DEVELOPMENT
GROUP, INC.

UNIflow II



Oswego 1967

Whitten, the industry's pioneer in the development of stainless steel gutter systems is committed to re-introducing the stainless steel gutter system and re-educating design professionals in the proper selection and application of such systems.

The Next Generation of **WHITTEN**[®] Stainless Steel Recirculation Systems

Since Whitten's[®] introduction to the commercial pool industry more than 45 years ago, stainless steel gutter systems have been installed on literally thousands of swimming pools throughout the world. Gutter systems have been offered by many different manufacturers in a wide variety of designs and configurations. Unfortunately, over the years, the primary reasons for specifying gutter systems, their proper sizing and design functions have been compromised by manufacturers and designers alike attempting to make basic systems adaptable to all pools without due understanding and consideration of varying flow rates, pool size, pool use, and the basic benefits of a custom perimeter recirculation system.

Stainless steel gutter systems are often viewed as commodity products that are all alike. At Whitten[®], this simply isn't the case.

Today many gutter systems are being sold that are far too small for the application, with multiple collector and return converters, resulting in a significant amount of expensive, buried pipe being included in new pool installations. In an effort to make gutter systems less expensive, many manufacturers have lost sight of the primary purpose of stainless steel gutter systems; that is, the near total elimination of buried perimeter piping. Early promoters of stainless steel gutter systems wisely touted the benefits of the "pipeless" pool.



Rutgers University 1985

In more recent years, the primary reason for specifying a stainless steel gutter seems to have been forgotten, thus resulting in the installation of systems that are inadequately sized for the application, will operate in a totally flooded condition and that include hundreds of feet of buried and inaccessible piping. To further exacerbate the problems with current thinking, many manufacturers are providing hydraulic calculations to establish the capacity of their gutter systems that seriously overstate the functional capacity of their gutter systems. This misrepresentation of a gutter's true carrying capacity results in installations being completed with systems that are woefully undersized and that could never perform adequately, let alone properly.



San Juan Natatorium 2007

The Whitten[®] Uniflow II stainless steel gutter represents the culmination of decades of innovation and experience in stainless steel gutter system technology.

UNI*f*LOW II

The Uniflow II Surge Recovery Gutter System at a Glance

Performance Advantages

Uniflow II gutter system provides today's athletes with a "fast pool". Properly sized Uniflow II gutters are designed to capture and retain the surface water turbulence created during competition swimming. This provides a smoother water surface, which is universally known to better swimmer's times. Proper gutter sizing and selection insures optimal performance. No two pools are alike and no generic sizing chart can provide the design professional with the information necessary to properly select a perimeter system. ADG associates are available to assist in designing a system that is specifically tailored to the needs of each project.

Design and Engineering Advantages

Let ADG select and specify the right Whitten® system for your pool project. Our dedicated and experienced team of aquatic facility designers is available to assist in the selection and specification of the Uniflow II system best suited to your application. Full specifications and construction drawings are available from our expert staff. Email or fax us your pool plans and we will tailor a system perfectly selected to your project.

Aesthetic and Maintenance Advantages

The Whitten® Uniflow II gutter and its PVC supply conduit eliminate the significant and often hidden problems associated with stainless steel supply tube gutters. It is well known that welded stainless steel supply tube gutters are subject to crevice corrosion in hidden welds, which allows pressurized pool water to leak out of the pool system. In many cases, this heated and treated pool water is actually leaking from the pool, which is not only costly in terms of lost water but could be undermining the integrity of the pool itself and even adjacent structures.

Whitten's® exclusive and patented Unitized Installation Option design allows designers to carry the primary pool finish onto the face of the gutter. Whether tile, plaster, painted concrete, or other finish, we have provided a means to make the pool's finish seamless, nearly to the overflow rim of the gutter. Not only does this option provide for a more aesthetically pleasing installation but the troublesome sealant joint, which can allow significant leakage, between the base of the gutter and the top of the concrete pool wall is completely eliminated, thus reducing ongoing maintenance.

Whitten® pioneered the one-piece Uni-Grate grating more than four decades ago. Many of the original Uni-Grate installations are still in service and performing today! This practically maintenance free grating provides a clean "look" while being easy to maintain. Additionally, our Uni-Grate is easy to remove and clean without tools and fastening systems. The Uni-Grate system provides for variable open area. While other manufacturer's grating provides only a fixed open area, with Uni-Grate, we have the ability to vary the available open area to fit with the designer's or Code requirements.



UNIFLOW II SRS Competition Model at a Glance



AQUATIC
DEVELOPMENT
GROUP, INC.

This gutter system has set our facility apart from all others in our community. I would definitely recommend the UNIFLOW II gutter system to anyone who is serious about wanting a "fast pool".

*Pat Ryan, Swim Coach
Washingtonville High School*



High Performance Competition Perimeter Recirculation Systems

It is often said, "fast kids make a fast pool". While we certainly cannot dispute this claim, fast kids in a fast pool set records.

When the primary purpose of a swimming pool is to support competitive swimming and training programs at the scholastic or collegiate level, only perimeter recirculation systems designed to maintain pool water level at the overflow rim, in accordance with NCAA and U.S. Swimming Rules, should be considered. Responding to this requirement, the Surge Recovery System (SRS) was conceived in 1979.

The high performance Surge Recovery System allows little or no buildup of water in the gutter drain channel thereby maintaining the pool water level at rimflow. The purpose of the Surge Recovery System is to avoid buildup of water within the gutter caused by competitive swim action (dynamic surge). This is accomplished by immediately transferring dynamic surge into the bottom of the pool.

The Whitten® UNIFLOW II is now in use in some of the most prestigious and fastest competitive swimming pools in the country such as: The Olympic Training Center, Colorado; Rutgers University, New Jersey; Lake Forest High School, Illinois; and Asphalt Green Aquatic Center, New York.

The performance result of the UNIFLOW II is to **maintain** the actual **water level** at the gutter overflow rim so that all wave action caused by static and dynamic surge is entrapped in the gutter with no rebound back into the pool. Water in excess of the pool's recirculating flow rate is returned by surge bypass pumps to the pool bottom. This assures absolute minimum turbulence during competition and ensures immediate return to quiescence when the swimmers leave the pool. While varying pool depths and racing lane lines are contributing factors to creating smooth, fast pools, **the proper design of the recirculation system is the single most significant factor in creating and maintaining a fast, smooth pool surface for high competition swimming.** The SRS system achieves unmatched surge recovery performance by virtue of its properly sized flow capacity in conjunction with its independent high capacity competition surge recovery pumping system.





SRS Competition Model at a Glance

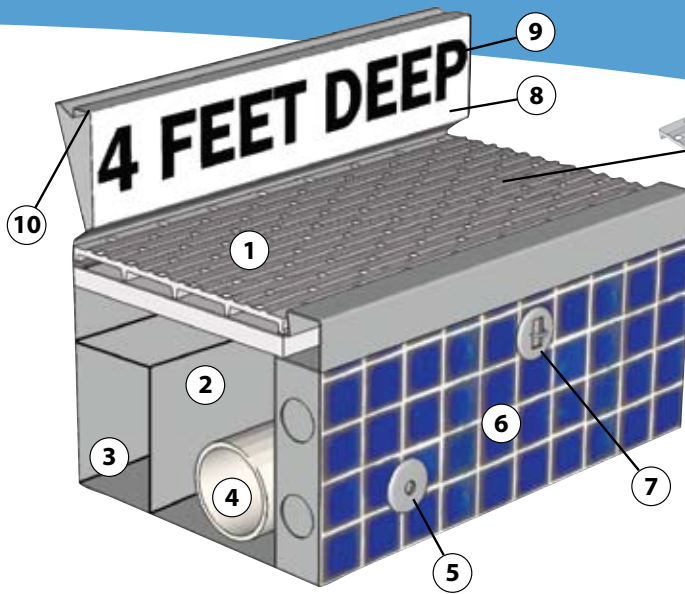

Whitten® Uni-Grate PVC Solid Core

Whitten® Recirculation Components

1. Slip-resistant, extruded PVC uni-grate
2. Primary overflow channel
3. Surge recovery channel
4. Filtered water return conduit
5. Filtered water inlet nozzle
6. Optional marcite plaster, paint or ceramic tile surface
7. Retractable lane line anchor
8. Stainless steel or tiled backsplash
9. Depth marker
10. Optional integral deck drain

1. As the pool moves from a state of quiescence to one of dynamic activity, surge is generated, increasing the water flow to the gutter and surge tank.

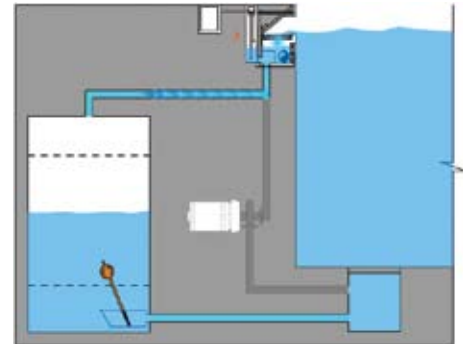
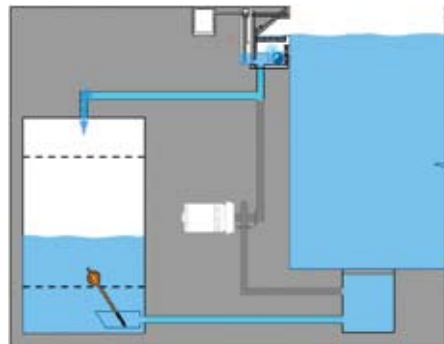

2. The increase in surge causes the water level within the gutter to rise until it connects the sensors circuit turning on the pump. The pump forces the excess water from the gutter back through the main drain and into the pool maintaining proper pool water level.

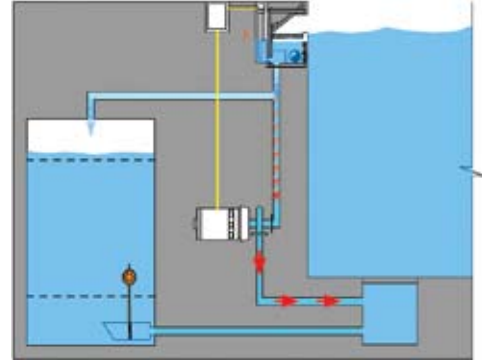
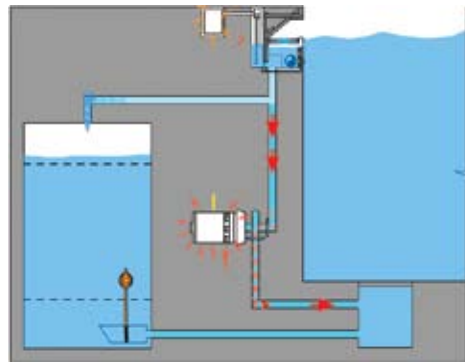

3. The water level having returned to optimum levels, breaks the sensors circuit, turning off the pump.

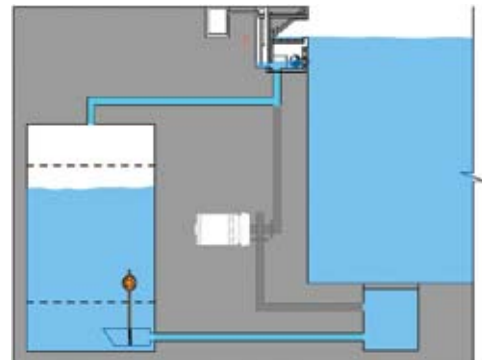
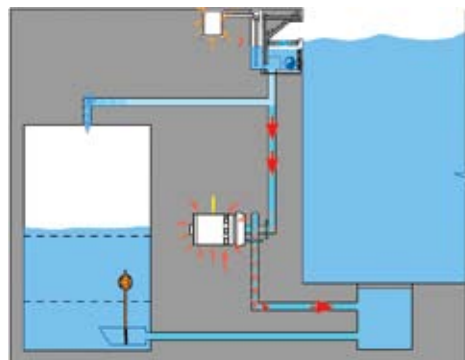

GUTTER DETAILS

Whitten® Uniflow II

Key Points: Economic Advantages

Provides a true "pipeless" perimeter. A properly sized Uniflow II gutter requires single supply and collection connection points with a very short run of piping to the mechanical system. With a piping chase located under the pool deck, there is no buried perimeter piping. The elimination of buried piping significantly reduces pool construction costs while eliminating future problems and expense associated with piping repairs. A standardized Uniflow II gutter channel design allows for fast and efficient

manufacturing, resulting in our ability to provide custom engineered gutters at a cost equal to or less than the industry's typically under designed stock systems. A gutter should be capable of flows in excess of 125% of the pools recirculation rate in a guaranteed non-flooded condition. The elimination of the extensive forming required to construct conventional concrete gutter systems means that the owner can receive the performance benefits associated with large concrete gutters, all while eliminating the cost of installing hundreds if not thousands of feet of troublesome buried piping. The installation of a Whitten® Uniflow II gutter requires no field welded stainless steel filtered water supply conduits. This results in a total elimination of potential crevice corrosion problems, the bane of stainless steel gutter systems over the years. With its unique PVC supply conduit housed inside the gutter trough, the supply conduit is never subjected to fatigue failure and replacement due to corrosion within the filtered water conduit. With proper estimating techniques, a Whitten® Uniflow II system may be installed at a lower cost than any conventional concrete gutter and buried supply system.

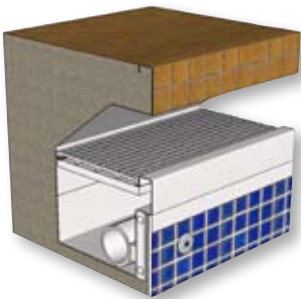
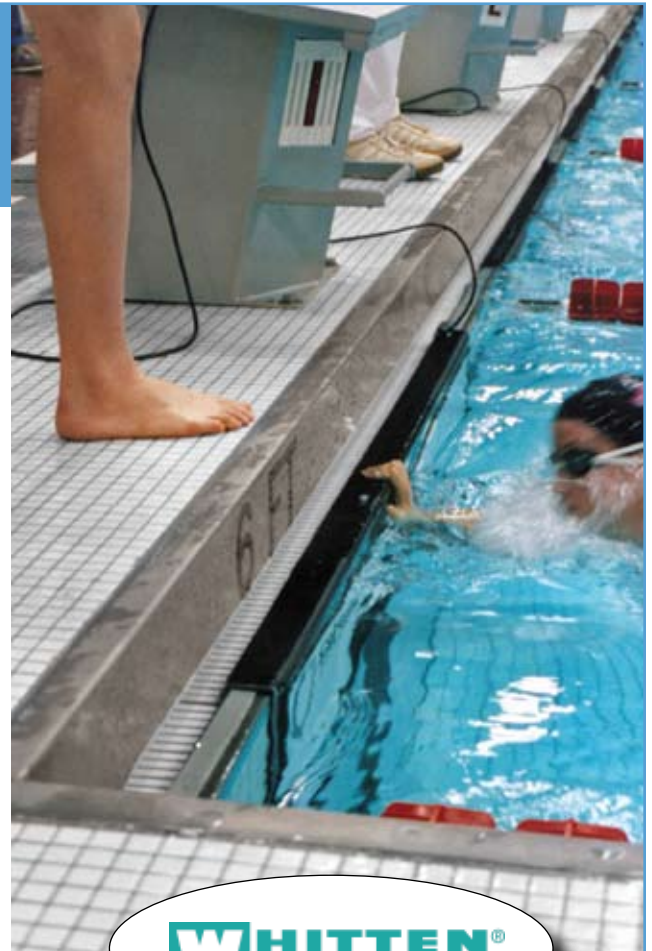

Fully Recessed with Concrete/Tile Backsplash

As with the semi-recessed concrete backsplash, this option is designed to provide all the benefits of a stainless steel competition pool gutter system with a minimum of exposed stainless steel.

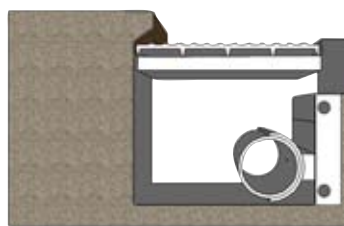
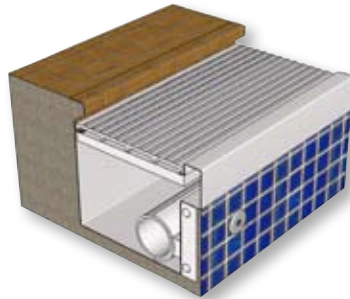

Roll-Out with Concrete/Tile Backsplash

Common to therapy pools, but often used in recreational or learn-to-swim environments, this configuration allows for the easiest pool access. Often utilized in conjunction with a movable pool floor, therapists and their patients can easily move from the pool deck onto the floor with minimum effort or the need for special lifts or costly, space consuming ramps. The 2" or less of freeboard is meant to provide a limited amount of splash out protection.

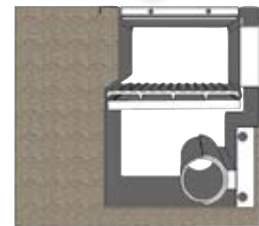
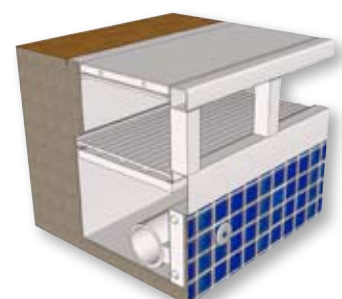

Competition End Wall

Used in combination with a standard semi-recessed configuration this option is often selected by pools designed for competitive swimming. The purpose of the competition end wall is to provide a visual target at the edge of the pool that backstrokers can easily identify as either the end of the course or a turn.

UNI*f*LOW II

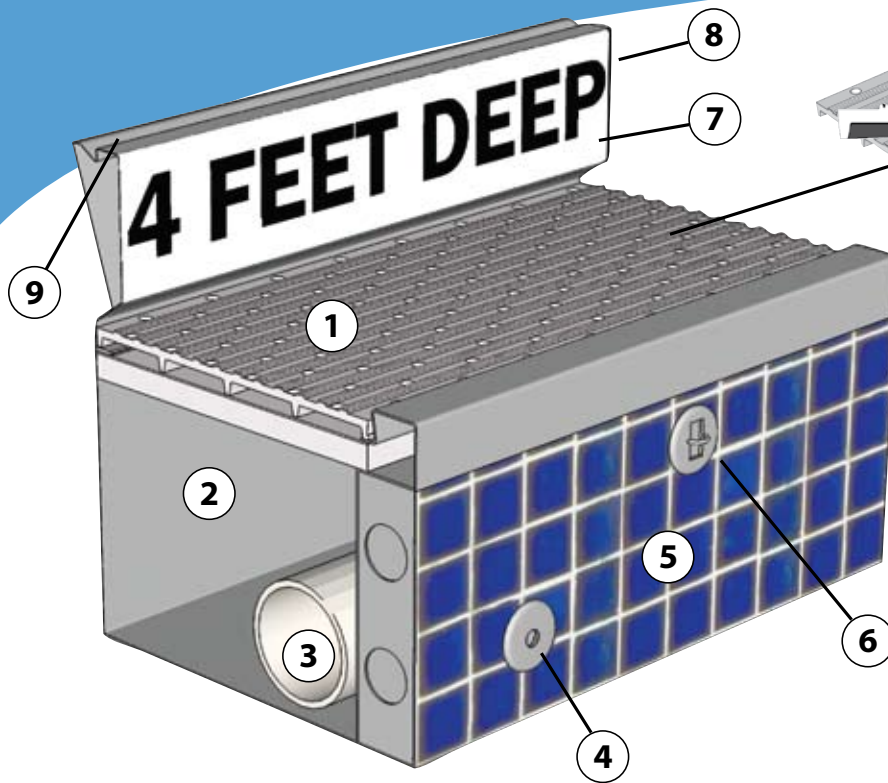

Whitten® Uni-Grate PVC Solid Core

Whitten® Recirculation Components

1. Slip-resistant, extruded PVC Uni-Grate
2. Primary overflow channel
3. Filtered water return conduit
4. Filtered water inlet nozzle
5. Optional marcite plaster, paint or ceramic tile surface
6. Retractable lane line anchor
7. Stainless steel or tiled backsplash
8. Depth marker
9. Optional integral deck drain



Semi-Recessed with S/S Backsplash

A traditional configuration, this style accommodates easy ingress and egress by means of the step it creates, which can also serve as a seat in the case of instruction or for simple recreation. In addition, the 6" of freeboard provided, minimizes the amount of water splashed onto the pool deck.



Semi-Recessed with Concrete/Tile Backsplash

This option acts exactly the same as the regular stainless steel backsplash option but it allows for a concrete deck to be poured and tiles up to the back of the gutter thereby minimizing the amount of exposed stainless for those who prefer the look of a tile finish.

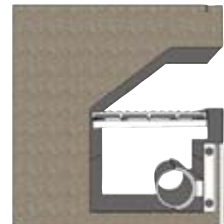
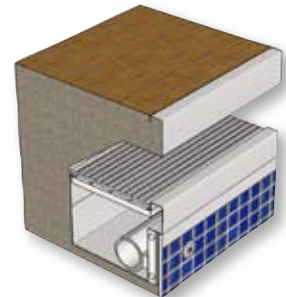

Fully Recessed with S/S Backsplash

Generally incorporated into high competition pools looking to maximize wave water retention. The top portion of this configuration also helps to swallow the waves as they enter the gutter area to provide a "fast" pool for competition (refer to the shortcomings of any passive system attempting to combat dynamic surge in the SRS portion of this brochure). As with the competition end wall, this configuration also provides swimmers and easily identified visual target.